

The 10kg AutoDose Washing machine with 6kg Dryer Combi with PowerCare technology, SpecialCare, Woolmark Blue accredited (Wash&Dry), ProSteam and 1600rpm spin speed.



Product Details

FEATURES

AutoDose system
AutoDose and intelligent sensors calculate the precise amount of detergent and softener required and dispense it automatically.

PowerCare
PowerCare premixes and activates detergent to deliver exceptional results, quickly and efficiently.

SpecialCare Wash-to-Dry
SpecialCare Wash-to-Dry adapts to fabric type for gentle, effective cleaning and drying.

ProSteam Technology
ProSteam helps reduce creases so less ironing is needed, helping clothes last longer.

PreciseLoad
PreciseLoad adapts energy and water usage to the load size for efficient, customised cleaning.

Hygiene
The Hygiene cycle eliminates more than 99.9% of common bacteria and viruses* while drying. Tested for Escherichia coli ATCC 11229, Candida albicans ATCC 10231, MS2 Bacteriophage DSM 13767 in external test performed by Swissatest Testmaterialien AG in 2021 (Test Report No. 20212038).

Woolmark Blue
Woolmark Blue-certified AEG washer dryers give you the confidence to wash & dry woollens.

CareDrum
The innovative CareDrum is designed to gently care for clothing, reducing fabric wear and tear.

BENEFITS

REMOVES BACTERIA AND VIRUSES*
Select Hygiene cycle for an ultra-clean Swissatest-certified washing performance. The temperature above 60C removes 99.99% of common bacteria and viruses* and reduces some allergens. Ideal for thoroughly clean clothing, bedlinen, quilts, and pillows. *Tested for Staphylococcus aureus, Enterococcus faecium, Candida albicans, Pseudomonas aeruginosa and MS2 Bacteriophage in external test performed by Swissatest Testmaterialien AG in 2021 (Test Report No. 202120117)

PRECISE DOSAGE. PRECISE CARE
Too little detergent can compromise your clean result, while too much can cause premature fabric wear and tear. AEG AutoDose removes the guesswork by automatically dispensing the precise detergent dosage. Intelligent sensors inside the machine weigh each load, identifying the optimal measure of detergent and softener for the cycle. Wear your clothes for longer and use up to 60% less detergent for a 2 kg load* with AutoDose. *According to an internal test method for the amount of detergent used for a 2kg load with AutoDose vs an average manual dose.

BOOST YOUR WASHING PERFORMANCE

PowerCare uses an advanced technique to premix and activate detergent for improved detergent efficacy, ensuring every fibre is reached, even at 30C. Delivers outstanding washing results in less than one hour.

WHY WASH WHEN YOU CAN STEAM

AEG ProSteam technology refreshes clothes so they are ready to wear in just 25 minutes save up to 96%* water. ProSteam efficiently reduces odours** and reduces creases in dry fabrics. A gentle steam cycle requires minimal to no ironing. *Internal test with a 1 kg load on the steam programme vs the delicates programme. **External test shows substantial reduction of cigarette smoke odour and kitchen odour in a Steam Refresh cycle by Laboratorio Olfattometria Dinamica in 2021 (Test Report No. LOD_RT_1070-21).

OPTIMISED FOR SMALL LOADS

PreciseLoad automatically adapts the cycle time, along with energy and water usage, in proportion to the size of the laundry load. So, you experience customised laundry cycles that save energy and water when washing and drying smaller loads.

The gentle way to care for wool

The Woolmark Blue certification in both washing and drying will treat each item in the gentlest possible manner, meaning you can safely wash and dry all of your hand wash woollen garments.

CUSTOMISED CARE FOR DELICATES

SpecialCare Wash-to-Dry adapts to each fabric type for gentle yet effective cleaning, from everyday cottons to delicate silks. The Woolmark Blue-certified AEG washer-dryer ensures safe, expert care of woollen apparel. Waterproof fabrics are restored and protected, so you can enjoy your outdoor clothing for longer.

DESIGNED TO CARE FOR CLOTHES

The innovative design of the CareDrum lets garments glide smoothly thanks to its elevated cushion-like drum pattern and optimised lifter paddle. A thin film of water covers the holes during washing, providing your fabrics with an even gentler laundry experience*. *Internal tests comparing the Care drum to the AEG ProTex drum.

Specifications

PRODUCT PROFILE

| | |
|---------------------------------|------------------------------------|
| Domestic warranty details (yrs) | 5 |
| Front Loader Type | combination front loader and dryer |
| Design family (eline) | Ruby |
| Capacity (Kg) | 10 |
| Frontloader Wash system | OKOMix,AutoDose |

DRYER

| | |
|---------------|---|
| Capacity (Kg) | 6 |
|---------------|---|

DRYING PROGRAMS

| | |
|-----------------|-----------------------------|
| Drying Programs | timed programs,auto sensing |
|-----------------|-----------------------------|

DIMENSIONS

PRODUCT

| | |
|-----------------------------------|------|
| Total height (mm) | 850 |
| Product Width with door open (mm) | 1101 |
| Total width (mm) | 600 |
| Total depth (mm) | 660 |
| Depth with hoses (mm) | 660 |

BUTTON FUNCTION

| | |
|----------------------------|---|
| Dimension Button Functions | power/on/off,Start/Pause,Time Dry,temperature settings,Dryness,Remote |
|----------------------------|---|

ENERGY FOR WASHING

| | |
|------------------------------|--------|
| Water Efficiency Star Rating | 4.5 |
| WELS Registration Number | C01752 |

ENERGY FOR WASHING

| | |
|----------------------------|----|
| Water Consumption (litres) | 86 |
|----------------------------|----|

| | |
|-------------------------------|---|
| Energy Efficiency Star Rating | 5 |
|-------------------------------|---|

| | |
|-----------------------------------|-----|
| Energy Consumption Warm (KWhr/yr) | 240 |
|-----------------------------------|-----|

| | |
|-----------------|----|
| Noise level dBA | 51 |
|-----------------|----|

ENERGY FOR DRYING

| | |
|-------------------------------|---|
| Energy Efficiency Star Rating | 3 |
|-------------------------------|---|

| | |
|------------------------------|-----|
| Energy Consumption (KWhr/yr) | 229 |
|------------------------------|-----|

| | |
|----------------------------|----|
| Water Consumption (litres) | 55 |
|----------------------------|----|

WASH PROGRAMS

| | |
|--------------------|----|
| Number of Programs | 10 |
|--------------------|----|

| | |
|---------------------------|---|
| Frontloader Wash programs | Delicate, synthetics, Cotton, steam refresh, OutDoor, OKO Power, rinse, Drain & Spin, Cottons Eco, Wool |
|---------------------------|---|

| | |
|--------------|--|
| Wash options | wash temperatures, Prewash, spin selection, Delay Start, Quick wash, Extra Rinse |
|--------------|--|

| | |
|-----------|---|
| Dispenser | pre-wash dispenser, Powder or liquid detergent dispenser, Fabric softener dispenser |
|-----------|---|

| | |
|-----------------------|---------------------|
| Wash and Dry Programs | Cottons, Synthetics |
|-----------------------|---------------------|

| | |
|----------------------|-------------------------|
| Wash and Dry options | Time Dry, Dryness Level |
|----------------------|-------------------------|

CONTROLS

| | |
|----------------------|--|
| Type of controls | electronic rotary,electronic touchscreen,electronic push button |
| Control panel colour | Stainless Steel with anti-fingerprint colour |
| Functions available | time remaining,fault diagnostic display,delay start,extra rinse,wash cycle progress indicator,door lock indicator,child lock indicator,spin speed indicator,Temperature,Steam,maximum load capacity indicator,load weight,Stain,OKOMix,Dryness level,Child Lock,Wash/Dry Mode,quick wash/time save,Anti-crease |
| Type of display | LED |

DOOR

| | |
|-------------|--------|
| Reversible | No |
| Door Colour | Silver |
| door lock | Yes |

TECHNICAL

| | |
|---------------------------------|----|
| Water pressure requirements min | 50 |
|---------------------------------|----|

BOWL

| | |
|---------------|-----------------|
| Drum material | stainless steel |
|---------------|-----------------|

CABINET

| | |
|------------------|--------------------------|
| Cabinet Colour | white |
| Cabinet material | painted galvanized steel |

SHIPPING

| | |
|----------------------|-------|
| Shipping Volume (m3) | 0.409 |
| Shipping Weight (Kg) | 83 |

TECHNICAL

| | |
|---------------------------------|-----|
| Water pressure requirements max | 800 |
|---------------------------------|-----|

| | |
|--------------|------|
| Water supply | cold |
|--------------|------|

| | |
|-------------------|-----|
| Inlet hose length | 150 |
|-------------------|-----|

| | |
|-------------------|-----|
| Drain hose length | 140 |
|-------------------|-----|

| | |
|---------------------|------|
| Service cord length | 2170 |
|---------------------|------|

| | |
|------------|--------------|
| Motor type | OkolInverter |
|------------|--------------|

| | |
|--------------------|------|
| Maximum spin speed | 1600 |
|--------------------|------|

| | |
|---------------------|-----|
| Variable spin speed | Yes |
|---------------------|-----|

SHIPPING

| | |
|-----------------------------|-----|
| Pack Dimensions Height (mm) | 900 |
|-----------------------------|-----|

| | |
|---------------------------|-----|
| Pack Dimension Width (mm) | 640 |
|---------------------------|-----|

| | |
|---------------------------|-----|
| Pack Dimension Depth (mm) | 710 |
|---------------------------|-----|

STUFFING QUANTITIES

| | |
|---------|-----|
| 40ft HC | 150 |
|---------|-----|

Dimensions

Model:
LWA8516O5A

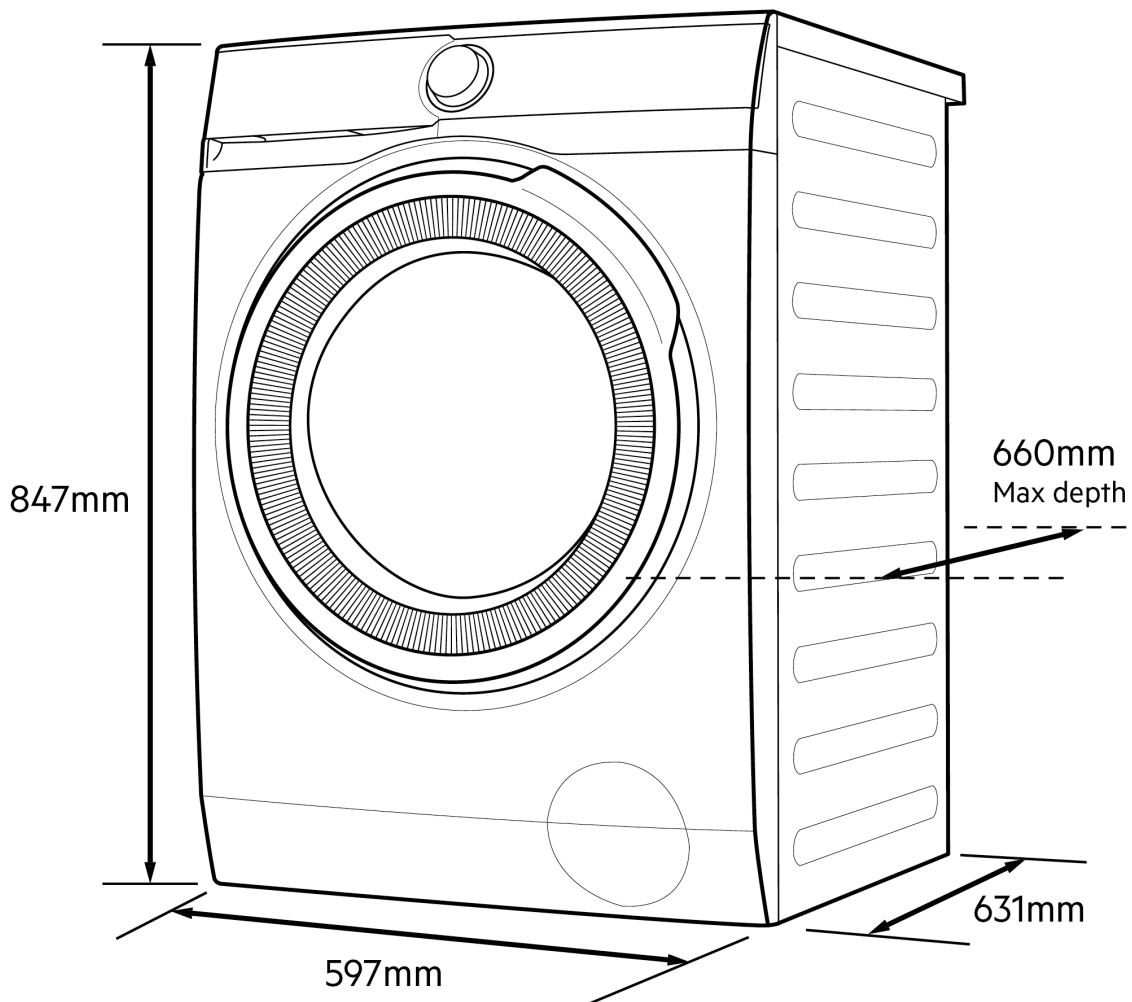

© 2023 Electrolux S.E.A PTE. LTD. AEG_IM_Diag_LWA8516O5A_Jul23

Terms and Conditions

IMPORTANT

This is a guide of product dimensions only. For complete installation instructions, refer to the manual provided with product.

PRODUCT INFORMATION

The descriptors and illustrations in this publication apply to the specific products and models described as at the date of issue. Under our policy of continuous product development, product specifications may change without notice. Prospective purchasers should therefore check with their retailer to ensure this publication correctly describes the products that are being offered for sale. All information supplied is to be used for general reference purposes only and is on the understanding that Electrolux Home Products Pty Ltd (Australia) and Electrolux (NZ) Ltd (New Zealand) will not be liable for any loss, liability or damage of whatever kind arising as a result of reliance on such information. Colours of products illustrated are as close as printing limitations allow. Electrolux will at all times comply with its obligations pursuant to law including Trade Practices (Australian Consumer Law) Act and Regulations.

WARRANTY

Electrolux Home Products warrants that for domestic applications the AEG appliances featured are free from defects in materials and workmanship for 5 years (3 months warranty for commercial applications). All warranties are subject to the conditions set out in the warranty card accompanying the product when purchased.

ELECTROLUX HOME PRODUCTS AUSTRALIA

telephone: 1300 363 664

fax: 1800 350 067

email: customercare@aegaustralia.com.au

web: www.aeg.com/au

ELECTROLUX HOME PRODUCTS NEW ZEALAND

telephone: 0800 10 66 10

fax: 09 573 2221

email: customercare@electrolux.co.nz

web: www.aeg.com/au