

SIDE BY SIDE COMBINATIONS

SBSef 7242



LIEBHERR

Quality, Design and Innovation

LIEBHERR SIDE BY SIDE COMBINATION SBSeF 7242



Smart Steel Doors No Frost 3 Year Warranty

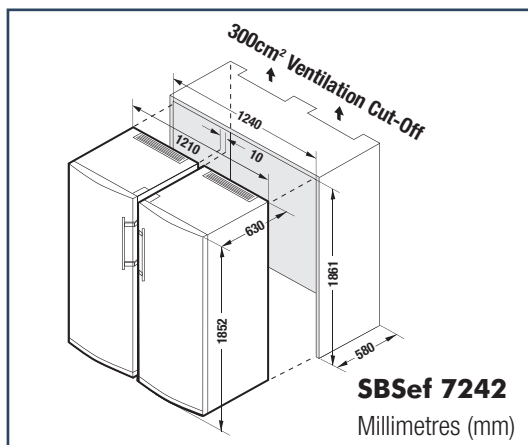

| Model | SBSeF 7242* | |
|---|---|---|
| *Side-by-Sides comprised of two models | SGNeF 3036 | SKeF 4260 |
| Type Finish | FS SmartSteel [®] (doors only) | FS SmartSteel [®] (doors only) |
| Energy consumption (kWh/yr) Star rating | 310kWh 3.5 | 279kWh 2.5 |
| Compressors | 1 | 1 |
| Total capacity litres (L) - Gross Net | 304 261 | 405 391 |
| Refrigerator gross (L) Refrigerator net (L) | - | 405 391 |
| Freezer gross (L) Freezer net (L) | 304 261 | - |
| MagicEye control system Display | SoftTouch LCD | SoftTouch LCD |
| Child proof setting for display & temp. | • | • |
| LED standard lighting | • | • |
| Aluminium handle - integrated opening device | • | • |
| Door open warning signal | • | • |
| Temperature alarm | • | - |
| Malfunction warning signal | • | • |

Refrigerator Features

| | | |
|-----------------------------------|---------|-------|
| Fruit & vegetable drawer | N/A | 2 |
| SuperCool | N/A | • |
| GlassLine shelves | N/A | • |
| Elegant holding columns | N/A | • |
| Bottle shelf Egg tray | - N/A | • • |
| Automatic refrigerator defrosting | N/A | • |

Freezer Features

| | | |
|---|------------|-----|
| Freezer defrosting | Frost Free | N/A |
| FrostSafe system with transparent drawers | • | N/A |
| Freezer drawers Ice cube drawer | 8 - | N/A |
| SuperFrost | • | N/A |
| 24hr freezing capacity (kg) | 20 | N/A |

Technical Information

| | | |
|---------------------------------|---------------|---------------|
| Default hinge | Left | Right |
| Voltage (V) Rated Current (A) | 220-240 1.3 | 220-240 1.2 |
| Made in | Germany | Germany |

KEY: FS = Freestanding, N/A = Not Applicable, ° = SmartSteel is only on doors, * = Freestanding side by sides consist of two Liebherr models. These models **can** be purchased separately. Cavity clearance for freestanding units please allow min. 50 mm above the unit if there is no ventilation cut-out.

Whilst every effort is made to ensure all specifications and information in this flyer are correct at time of printing, Andi-Co Australia Pty. Ltd. reserve the right to make changes without notification. Where actual appliance measurements, specifications and ratings are crucial, we recommend that the actual appliance installation instructions that accompany each appliance be checked. Andi-Co Australia will not be liable for any loss.